

## 4"-12" HSF 250 LINE STOP FITTINGS

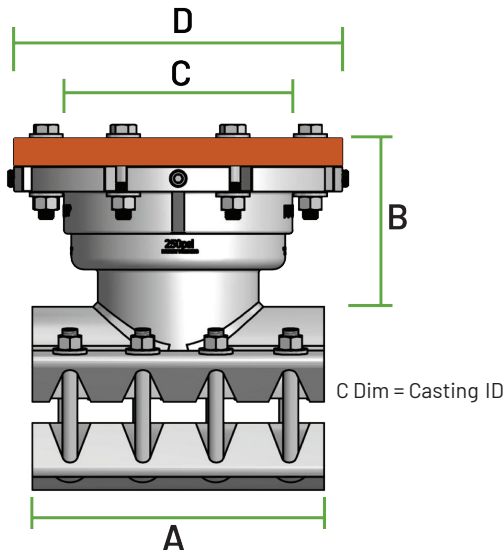
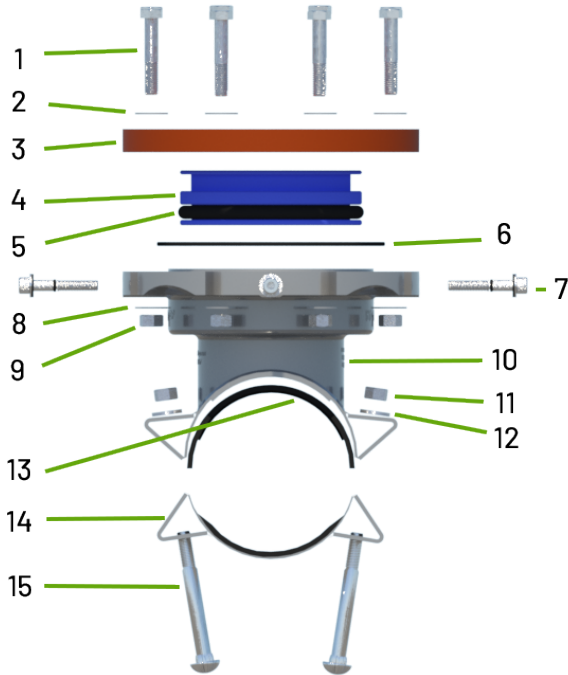

HSF 250 LINE STOP ASSEMBLY			
ITEM	QTY	PART NUMBER	MATERIAL
1	8	BLIND FLANGE BOLTS **	304 STAINLESS STEEL*
2	8	BLIND FLANGE WASHERS**	304 STAINLESS STEEL
3	1	BLIND FLANGE	EPOXY COATED CARBON STEEL
4	1	PIN STYLE COMPLETION PLUG	REINFORCED COMPOSITE POLYMER
5	1	COMPLETION PLUG O-RING	RUBBER, BLACK BUNA-N
6	1	FLANGE O-RING	RUBBER, BLACK BUNA-N
7	4	COMPLETION PIN ASSEMBLY	300 SERIES STAINLESS STEEL
8	8	BLIND FLANGE WASHERS (8) **	304 STAINLESS STEEL
9	8	BLIND FLANGE NUT (8) **	304 STAINLESS STEEL*
10	1	HSF 250 FITTING BODY	304 STAINLESS STEEL
11	8	BODY MOUNT NUT **	304 STAINLESS STEEL*
12	8	BODY MOUNT WASHERS **	304 STAINLESS STEEL
13	1	TOP BODY SEALING GASKET	RUBBER, BLACK NBR
14	1	BOTTOM MOUNTING BODY WITH GASKET	304 STAINLESS STEEL / BLACK NBR
15	8	BODY MOUNT CARRIAGE BOLTS	304 STAINLESS STEEL*

\* Coated to prevent galling.

\*\* 8" fitting requires 10 mounting bolts, nuts, and washers. 10" and 12" fittings require 14 mounting bolts, nuts, and washers; 12 blind flange bolts and nuts; and 24 blind flange washers.

WEIGHTS AND DIMS					
Size	A	B	C	D	Approx. Weight
4"	12"	7.501"	8.4"	13.5"	113 lbs.
6"	12"	6.92"	8.4"	13.5"	118 lbs.
8"	16"	5.571"	8.4"	13.5"	126 lbs.
10"	24"	7.5"	12.4"	19"	240 lbs.
12"	24"	7.5"	12.4"	19"	250 lbs.

OTHER SPECIFICATIONS
Valve Body Minimum Test Pressure: 1.5 times system working pressure
Valve Body Maximum Test Pressure: 375 psi
Option available to meet "Build America, Buy America Act", "Buy American Act", "Buy America", and "American Iron and Steel" requirements.
Maximum Working Pressure: 250 psi
The 4"-12" HSF250 is NSF/ANSI Standard 61 and NSF/ANSI Standard 372 to meet the regulatory requirements for the U.S. and Canada, assuring safe use in drinking water systems.

Proprietary Information: This property of Hydra-Stop shall not be used, reproduced, or distributed without written consent. All design and invention rights are reserved. Covered by United States Patent No. 9,829,141. Specifications subject to change without notice. Publication Date: January 2026

**APPROVED BY:**

Name: \_\_\_\_\_

Title: \_\_\_\_\_

Date: \_\_\_\_/\_\_\_\_/\_\_\_\_